

HC HYDRAULIC CRANE
INDUSTRIE

HC 45



I MIGLIORI PRODOTTI DI QUALITÀ | BEST QUALITY PRODUCTS

www.hcindustrie.com

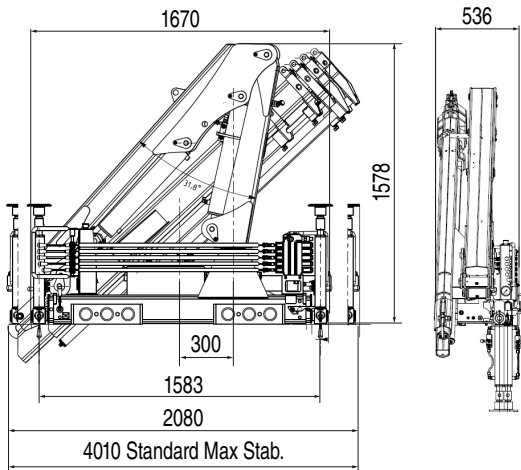

GRU STANDARD Std Crane - Grue Standard - Grua standard

Bracci stabilizzatori standard Std outrigger booms - Bras de stabilisation std. - Brazos estabilizadores std.	mm. 4010
Angolo di rotazione Slewing angle - Angle de rotation - Giro	365°
Tiranti di ancoraggio (kg. 15) Tie rods for anchorage - Tirants d'ancrage - Tirantes de fijación	n°6 M18x1,5 mat. 39 Ni Cr Mo3
Portata raccomandata Recommended oil flow - Débit recommandé - Caudal requerido	l/min. 15
Capacità del serbatoio Tank capacity - Capacité du réservoir - Capacidad del depósito de aceite	lt. 20
Pressione massima Rated pressure - Pression maxi - Presión máxima	bar 270

PM = punto morto di rotazione
Dead point position - Point mort de rotation
Punto muerto de giro

+ 170 mm
con canalina
with cable tray

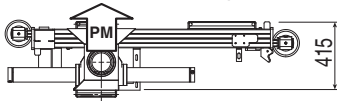

HC 45 A1

Massa della gru senza olio nel serbatoio

Overhang crane without oil in the tank - Poids de la grue sans huile dans le réservoir - Peso de la grua sin aceite en el depósito

Kg. 515

Momento di sollevamento massimo

Maximum lifting moment - Moment de levage maxi - Momento de elevación máxima

tm 3,9

Sbraccio oleodinamico

Maximum hydraulic reach - Déport hydraulique - Alcance hidráulico

Orizzontale Horizontal - Horizontal - Horizontal

m. 4,74

Verticale Vertical - Vertical - Vertical

m. 7,29

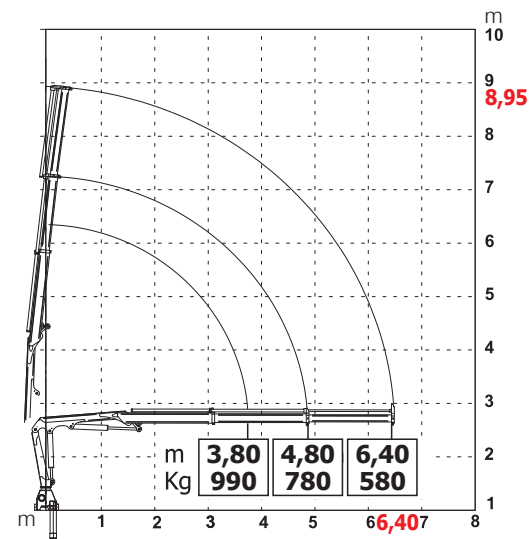
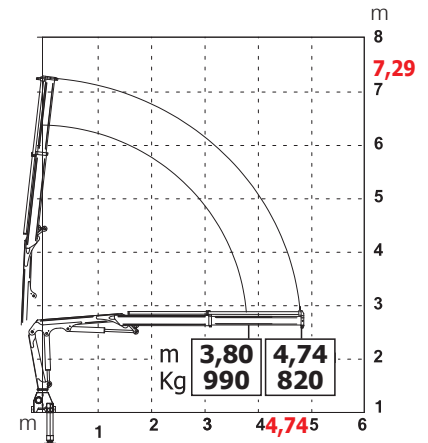

HC 45 A2

Massa della gru senza olio nel serbatoio

Overhang crane without oil in the tank - Poids de la grue sans huile dans le réservoir - Peso de la grua sin aceite en el depósito

Kg. 560

Momento di sollevamento massimo

Maximum lifting moment - Moment de levage maxi - Momento de elevación máxima

tm 3,8

Sbraccio oleodinamico

Maximum hydraulic reach - Déport hydraulique - Alcance hidráulico

Orizzontale Horizontal - Horizontal - Horizontal

m. 6,40

Verticale Vertical - Vertical - Vertical

m. 8,95

HC 45 A3

Massa della gru senza olio nel serbatoio

Overhang crane without oil in the tank - Poids de la grue sans huile dans le réservoir - Peso de la grua sin aceite en el depósito

Kg. 600

Momento di sollevamento massimo

Maximum lifting moment - Moment de levage maxi - Momento de elevación máxima

tm 3,8

Sbraccio oleodinamico

Maximum hydraulic reach - Déport hydraulique - Alcance hidráulico

Orizzontale Horizontal - Horizontal - Horizontal

m. 7,77

Verticale Vertical - Vertical - Vertical

m. 10,32

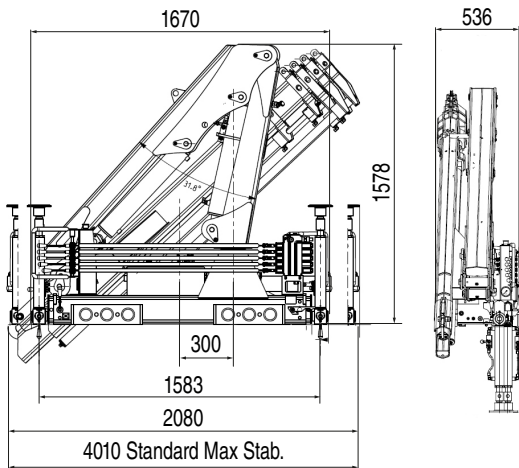
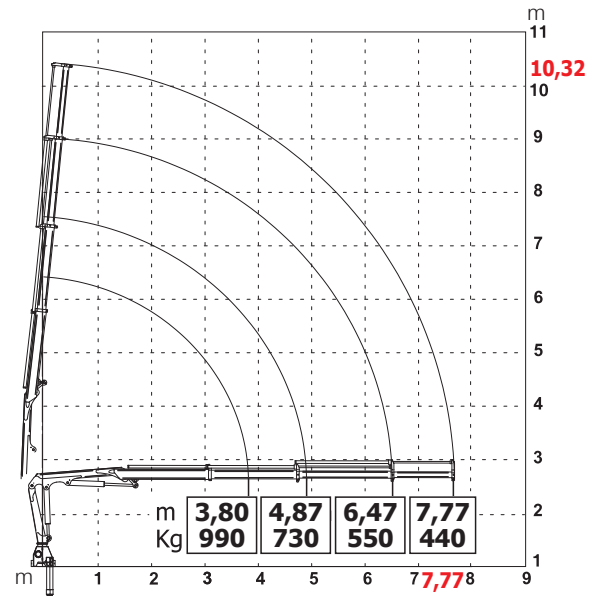

GRU STANDARD Std Crane - Grue Standard - Grua standard

Bracci stabilizzatori standard

Std outrigger booms - Bras de stabilisation std. - Brazos estabilizadores std.

mm. 4010

Angolo di rotazione

Slewing angle - Angle de rotation - Giro

365°

Tiranti di ancoraggio (kg. 15)

Tie rods for anchorage - Tirants d'ancrage - Tirantes de fijación

n°6 M18x1,5

mat. 39 Ni Cr Mo3

Portata raccomandata

Recommended oil flow - Débit recommandé - Caudal requerido

l/min. 15

Capacità del serbatoio

Tank capacity - Capacité du réservoir - Capacidad del depósito de aceite

lt. 20

Pressione massima

Rated pressure - Pression maxi - Presión máxima

bar 270

PM = punto morto di rotazione
Dead point position - Point mort de rotation
Punto muerto de giro

+ 170 mm
con canalina
with cable tray

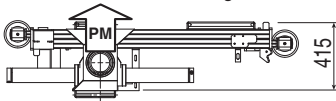

HC 45 A4

Massa della gru senza olio nel serbatoio

Overhang crane without oil in the tank - Poids de la grue sans huile dans le réservoir - Peso de la grua sin aceite en el depósito

Kg. 635

Momento di sollevamento massimo

Maximum lifting moment - Moment de levage maxi - Momento de elevación máxima

tm 3,8

Sbraccio oleodinamico

Maximum hydraulic reach - Déport hydraulique - Alcance hidráulico

Orizzontale Horizontal - Horizontal - Horizontal

m. 9,12

Verticale Vertical - Vertical - Vertical

m. 11,67

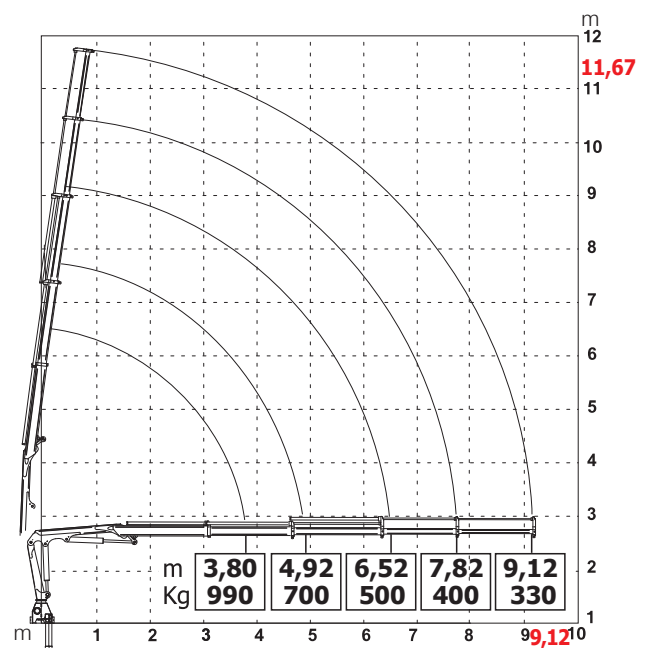



TUTTI I DATI TECNICI POSSONO ESSERE CAMBIATI SENZA PREAVISO - ALL TECHNICAL DATA CAN BE CHANGED WITHOUT NOTICE
TOUS LES DONNEES TECHNIQUES PEUVENT ETRE MODIFIEES SANS PREAVIS - TODOS LOS DATOS TECNICOS PUEDEN SER CAMBIADOS SIN AVISO

HC INDUSTRIE S.R.L.

Via Luciano Romagnoli, 1

42023 Cadelbosco di Sopra Reggio Emilia, Z.I. La Madonnina (RE)

Phone +39.0522.911729 - Fax +39.0522.404040

Email: commerciale@hcindustrie.com - Website: www.hcindustrie.com

